



US010453904B2

(12) **United States Patent**
Chaji et al.

(10) **Patent No.:** **US 10,453,904 B2**
(45) **Date of Patent:** ***Oct. 22, 2019**

(54) **MULTI-FUNCTIONAL ACTIVE MATRIX ORGANIC LIGHT-EMITTING DIODE DISPLAY**

(71) Applicant: **Ignis Innovation Inc.**, Waterloo (CA)

(72) Inventors: **Gholamreza Chaji**, Waterloo (CA);
Baolin Tian, Kitchener (CA)

(73) Assignee: **Ignis Innovation Inc.**, Waterloo (CA)

(*) Notice: Subject to any disclaimer, the term of this patent is extended or adjusted under 35 U.S.C. 154(b) by 0 days.

This patent is subject to a terminal disclaimer.

(21) Appl. No.: **16/107,672**

(22) Filed: **Aug. 21, 2018**

(65) **Prior Publication Data**

US 2018/0358419 A1 Dec. 13, 2018

Related U.S. Application Data

(63) Continuation of application No. 15/783,662, filed on Oct. 13, 2017, now Pat. No. 10,079,269, which is a (Continued)

(51) **Int. Cl.**

H01L 27/32 (2006.01)
G09G 3/3225 (2016.01)

(Continued)

(52) **U.S. Cl.**

CPC **H01L 27/3227** (2013.01); **G06F 3/042** (2013.01); **G06F 3/0412** (2013.01);
(Continued)

(58) **Field of Classification Search**

CPC H01L 27/3209; H01L 27/3227; H01L 27/323; H01L 31/022425; H01L 31/04;
(Continued)

(56) **References Cited**

U.S. PATENT DOCUMENTS

4,354,162 A 10/1982 Wright
4,758,831 A 7/1988 Kasahara
(Continued)

FOREIGN PATENT DOCUMENTS

CA 1294034 1/1992
CA 2109951 11/1992
(Continued)

OTHER PUBLICATIONS

Ahnood et al.: "Effect of threshold voltage instability on field effect mobility in thin film transistors deduced from constant current measurements"; dated Aug. 2009 (3 pages).

(Continued)

Primary Examiner — Amare Mengistu

Assistant Examiner — Gloryvid Figueroa-Gibson

(74) *Attorney, Agent, or Firm* — Stratford Managers Corporation

(57) **ABSTRACT**

A multi-functional active matrix display comprises a transparent front sheet, a semi-transparent layer of light emissive devices adjacent the rear side of the front sheet and forming a matrix of display pixels, and a solar cell layer located behind the light emissive devices for converting both ambient light and internal light from the light emissive devices into electrical energy, the solar cell layer including an array of electrodes on the front surface of the solar cell layer for use in detecting the location of a change in the amount of light impinging on a portion of the front surface of the solar cell layer.

21 Claims, 3 Drawing Sheets

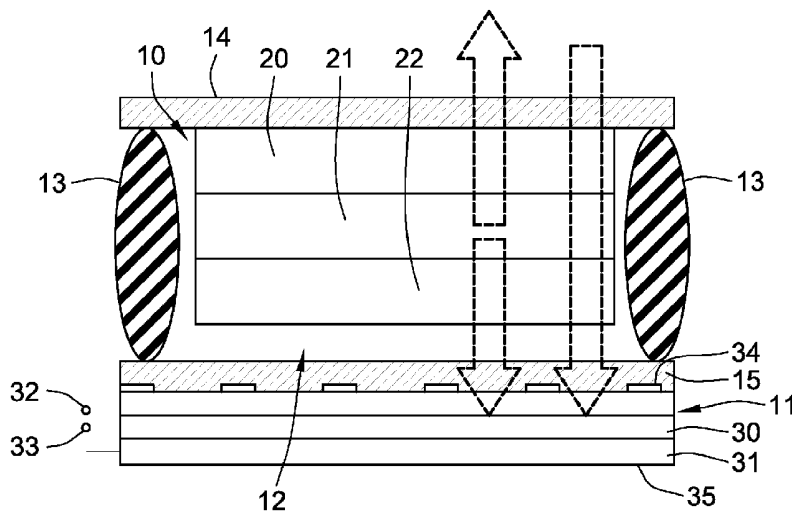

- Related U.S. Application Data**
- continuation of application No. 15/174,174, filed on Jun. 6, 2016, now Pat. No. 9,818,806, which is a continuation of application No. 13/689,241, filed on Nov. 29, 2012, now Pat. No. 9,385,169.
- (60) Provisional application No. 61/564,634, filed on Nov. 29, 2011.
- (51) **Int. Cl.**
G06F 3/042 (2006.01)
G06F 3/041 (2006.01)
H01L 51/52 (2006.01)
H01L 27/28 (2006.01)
G09G 3/00 (2006.01)
G09G 3/34 (2006.01)
H01L 51/00 (2006.01)
H01L 51/50 (2006.01)
- (52) **U.S. Cl.**
CPC **G06F 3/0421** (2013.01); **G09G 3/003** (2013.01); **G09G 3/3225** (2013.01); **G09G 3/3406** (2013.01); **H01L 27/288** (2013.01); **H01L 27/323** (2013.01); **H01L 51/525** (2013.01); **H01L 51/5206** (2013.01); **H01L 51/5234** (2013.01); **H01L 51/5246** (2013.01); **H01L 51/5284** (2013.01); **G09G 2354/00** (2013.01); **G09G 2358/00** (2013.01); **H01L 51/006** (2013.01); **H01L 51/0058** (2013.01); **H01L 51/0071** (2013.01); **H01L 51/0072** (2013.01); **H01L 51/0081** (2013.01); **H01L 51/5012** (2013.01); **H01L 51/5056** (2013.01); **H01L 51/5072** (2013.01); **H01L 51/5092** (2013.01); **H01L 51/524** (2013.01); **H01L 2251/301** (2013.01); **H01L 2251/305** (2013.01); **H01L 2251/308** (2013.01); **H01L 2251/5323** (2013.01); **H01L 2251/558** (2013.01)
- (58) **Field of Classification Search**
CPC F21Y 2101/02; F21Y 2105/00; G02F 2001/133618; G09F 13/22; G09F 27/007; G09F 9/33; G06F 3/0412; G06F 3/0421; G06F 3/042; G06F 2203/04104; G06F 1/3203; G06F 1/3262; G06F 2203/04103; G09G 3/3225; G09G 2300/0866; G09G 2330/021; G09G 2360/144; G09G 2360/148; H05B 33/14; H04N 5/30; H04N 5/374; H04N 5/2251; A61B 1/0684; A61B 5/06
USPC 345/39-46, 82, 173-178; 257/84, 642; 178/18.01, 18.09, 18.11
See application file for complete search history.
- (56) **References Cited**
U.S. PATENT DOCUMENTS
- | | | | | | | | |
|-----------|---|---------|-----------|-----------|----|---------|-----------|
| 4,963,860 | A | 10/1990 | Stewart | 5,686,935 | A | 11/1997 | Weisbrod |
| 4,975,691 | A | 12/1990 | Lee | 5,712,653 | A | 1/1998 | Katoh |
| 4,996,523 | A | 2/1991 | Bell | 5,714,968 | A | 2/1998 | Ikeda |
| 5,051,739 | A | 9/1991 | Hayashida | 5,747,928 | A | 5/1998 | Shanks |
| 5,222,082 | A | 6/1993 | Plus | 5,748,160 | A | 5/1998 | Shieh |
| 5,266,515 | A | 11/1993 | Robb | 5,784,042 | A | 7/1998 | Ono |
| 5,498,880 | A | 3/1996 | Lee | 5,790,234 | A | 8/1998 | Matsuyama |
| 5,589,847 | A | 12/1996 | Lewis | 5,815,303 | A | 9/1998 | Berlin |
| 5,619,033 | A | 4/1997 | Weisfield | 5,870,071 | A | 2/1999 | Kawahata |
| 5,648,276 | A | 7/1997 | Hara | 5,874,803 | A | 2/1999 | Garbuzov |
| 5,670,973 | A | 9/1997 | Bassetti | 5,880,582 | A | 3/1999 | Sawada |
| 5,684,365 | A | 11/1997 | Tang | 5,899,461 | A | 5/1999 | Yomogita |
| | | | | 5,903,248 | A | 5/1999 | Irwin |
| | | | | 5,917,280 | A | 6/1999 | Burrows |
| | | | | 5,923,794 | A | 7/1999 | McGrath |
| | | | | 5,952,789 | A | 9/1999 | Stewart |
| | | | | 5,990,629 | A | 11/1999 | Yamada |
| | | | | 6,023,259 | A | 2/2000 | Howard |
| | | | | 6,069,365 | A | 5/2000 | Chow |
| | | | | 6,081,131 | A | 6/2000 | Ishii |
| | | | | 6,091,203 | A | 7/2000 | Kawashima |
| | | | | 6,097,360 | A | 8/2000 | Holloman |
| | | | | 6,144,222 | A | 11/2000 | Ho |
| | | | | 6,157,583 | A | 12/2000 | Starnes |
| | | | | 6,166,489 | A | 12/2000 | Thompson |
| | | | | 6,177,915 | B1 | 1/2001 | Beeteson |
| | | | | 6,225,846 | B1 | 5/2001 | Wada |
| | | | | 6,229,508 | B1 | 5/2001 | Kane |
| | | | | 6,232,939 | B1 | 5/2001 | Saito |
| | | | | 6,246,180 | B1 | 6/2001 | Nishigaki |
| | | | | 6,252,248 | B1 | 6/2001 | Sano |
| | | | | 6,259,424 | B1 | 7/2001 | Kurogane |
| | | | | 6,274,887 | B1 | 8/2001 | Yamazaki |
| | | | | 6,288,696 | B1 | 9/2001 | Holloman |
| | | | | 6,300,928 | B1 | 10/2001 | Kim |
| | | | | 6,303,963 | B1 | 10/2001 | Ohtani |
| | | | | 6,306,694 | B1 | 10/2001 | Yamazaki |
| | | | | 6,307,322 | B1 | 10/2001 | Dawson |
| | | | | 6,316,786 | B1 | 11/2001 | Mueller |
| | | | | 6,320,325 | B1 | 11/2001 | Cok |
| | | | | 6,323,631 | B1 | 11/2001 | Juang |
| | | | | 6,323,832 | B1 | 11/2001 | Nishizawa |
| | | | | 6,345,085 | B1 | 2/2002 | Yeo |
| | | | | 6,348,835 | B1 | 2/2002 | Sato |
| | | | | 6,365,917 | B1 | 4/2002 | Yamazaki |
| | | | | 6,373,453 | B1 | 4/2002 | Yudasaka |
| | | | | 6,384,427 | B1 | 5/2002 | Yamazaki |
| | | | | 6,392,617 | B1 | 5/2002 | Gleason |
| | | | | 6,399,988 | B1 | 6/2002 | Yamazaki |
| | | | | 6,414,661 | B1 | 7/2002 | Shen |
| | | | | 6,420,758 | B1 | 7/2002 | Nakajima |
| | | | | 6,420,834 | B2 | 7/2002 | Yamazaki |
| | | | | 6,420,988 | B1 | 7/2002 | Azami |
| | | | | 6,433,488 | B1 | 8/2002 | Bu |
| | | | | 6,445,376 | B2 | 9/2002 | Parrish |
| | | | | 6,468,638 | B2 | 10/2002 | Jacobsen |
| | | | | 6,489,952 | B1 | 12/2002 | Tanaka |
| | | | | 6,501,098 | B2 | 12/2002 | Yamazaki |
| | | | | 6,501,466 | B1 | 12/2002 | Yamagashi |
| | | | | 6,512,271 | B1 | 1/2003 | Yamazaki |
| | | | | 6,518,594 | B1 | 2/2003 | Nakajima |
| | | | | 6,524,895 | B2 | 2/2003 | Yamazaki |
| | | | | 6,531,713 | B1 | 3/2003 | Yamazaki |
| | | | | 6,559,594 | B2 | 5/2003 | Fukunaga |
| | | | | 6,573,195 | B1 | 6/2003 | Yamazaki |
| | | | | 6,573,584 | B1 | 6/2003 | Nagakari |
| | | | | 6,576,926 | B1 | 6/2003 | Yamazaki |
| | | | | 6,577,302 | B2 | 6/2003 | Hunter |
| | | | | 6,580,408 | B1 | 6/2003 | Bae |
| | | | | 6,580,657 | B2 | 6/2003 | Sanford |
| | | | | 6,583,775 | B1 | 6/2003 | Sekiya |
| | | | | 6,583,776 | B2 | 6/2003 | Yamazaki |
| | | | | 6,587,086 | B1 | 7/2003 | Koyama |
| | | | | 6,593,691 | B2 | 7/2003 | Nishi |
| | | | | 6,594,606 | B2 | 7/2003 | Everitt |
| | | | | 6,597,203 | B2 | 7/2003 | Forbes |
| | | | | 6,611,108 | B2 | 8/2003 | Kimura |
| | | | | 6,617,644 | B1 | 9/2003 | Yamazaki |
| | | | | 6,618,030 | B2 | 9/2003 | Kane |

(56)

References Cited

U.S. PATENT DOCUMENTS

6,641,933	B1	11/2003	Yamazaki	7,619,594	B2	11/2009	Hu
6,661,180	B2	12/2003	Koyama	7,619,597	B2	11/2009	Nathan
6,661,397	B2	12/2003	Mikami	7,697,052	B1	4/2010	Yamazaki
6,670,637	B2	12/2003	Yamazaki	7,825,419	B2	11/2010	Yamagata
6,677,713	B1	1/2004	Sung	7,859,492	B2	12/2010	Kohno
6,680,577	B1	1/2004	Inukai	7,868,859	B2	1/2011	Tomida
6,687,266	B1	2/2004	Ma	7,876,294	B2	1/2011	Sasaki
6,690,344	B1	2/2004	Takeuchi	7,948,170	B2	5/2011	Striakhilev
6,693,388	B2	2/2004	Oomura	7,969,390	B2	6/2011	Yoshida
6,693,610	B2	2/2004	Shannon	7,995,010	B2	8/2011	Yamazaki
6,697,057	B2	2/2004	Koyama	8,044,893	B2	10/2011	Nathan
6,720,942	B2	4/2004	Lee	8,115,707	B2	2/2012	Nathan
6,734,636	B2	5/2004	Sanford	8,378,362	B2	2/2013	Heo
6,738,034	B2	5/2004	Kaneko	8,493,295	B2	7/2013	Yamazaki
6,738,035	B1	5/2004	Fan	8,497,525	B2	7/2013	Yamagata
6,771,028	B1	8/2004	Winters	8,643,028	B2	2/2014	Ban
6,777,712	B2	8/2004	Sanford	9,385,169	B2	7/2016	Chaji
6,780,687	B2	8/2004	Nakajima	9,606,607	B2	3/2017	Chaji
6,806,638	B2	10/2004	Lih	9,633,597	B2	4/2017	Nathan
6,806,857	B2	10/2004	Sempel	9,721,505	B2	8/2017	Chaji et al.
6,809,706	B2	10/2004	Shimoda	9,728,135	B2	8/2017	Nathan
6,859,193	B1	2/2005	Yumoto	9,741,292	B2	8/2017	Nathan
6,861,670	B1	3/2005	Ohtani	2001/0002703	A1	6/2001	Koyama
6,873,117	B2	3/2005	Ishizuka	2001/0004190	A1	6/2001	Nishi
6,873,320	B2	3/2005	Nakamura	2001/0013806	A1	8/2001	Notani
6,878,968	B1	4/2005	Ohnuma	2001/0015653	A1	8/2001	De Jong
6,909,114	B1	6/2005	Yamazaki	2001/0020926	A1	9/2001	Kujik
6,909,419	B2	6/2005	Zavracky	2001/0024186	A1	9/2001	Kane
6,919,871	B2	7/2005	Kwon	2001/0026127	A1	10/2001	Yoneda
6,937,215	B2	8/2005	Lo	2001/0026179	A1	10/2001	Saeki
6,940,214	B1	9/2005	Komiya	2001/0026257	A1	10/2001	Kimura
6,943,500	B2	9/2005	Lechevalier	2001/0030323	A1	10/2001	Ikeda
6,954,194	B2	10/2005	Matsumoto	2001/0033199	A1	10/2001	Aoki
6,956,547	B2	10/2005	Bae	2001/0038098	A1	11/2001	Yamazaki
6,995,510	B2	2/2006	Murakami	2001/0043173	A1	11/2001	Troutman
6,995,519	B2	2/2006	Arnold	2001/0045929	A1	11/2001	Prache
7,022,556	B1	4/2006	Adachi	2001/0052600	A1	12/2001	Sempel
7,023,408	B2	4/2006	Chen	2001/0052898	A1	12/2001	Osame
7,027,015	B2	4/2006	Booth	2002/0000576	A1	1/2002	Inukai
7,034,793	B2	4/2006	Sekiya	2002/0011796	A1	1/2002	Koyama
7,088,051	B1	8/2006	Cok	2002/0011799	A1	1/2002	Kimura
7,106,285	B2	9/2006	Naugler	2002/0011981	A1	1/2002	Kujik
7,116,058	B2	10/2006	Lo	2002/0015031	A1	2/2002	Fujita
7,129,914	B2	10/2006	Knapp	2002/0015032	A1	2/2002	Koyama
7,129,917	B2	10/2006	Yamazaki	2002/0030528	A1	3/2002	Matsumoto
7,141,821	B1	11/2006	Yamazaki	2002/0030647	A1	3/2002	Hack
7,161,566	B2	1/2007	Cok	2002/0036463	A1	3/2002	Yoneda
7,193,589	B2	3/2007	Yoshida	2002/0047852	A1	4/2002	Inukai
7,199,516	B2	4/2007	Seo	2002/0048829	A1	4/2002	Yamazaki
7,220,997	B2	5/2007	Nakata	2002/0050795	A1	5/2002	Imura
7,235,810	B1	6/2007	Yamazaki	2002/0053401	A1	5/2002	Ishikawa
7,245,277	B2	7/2007	Ishizuka	2002/0070909	A1	6/2002	Asano
7,248,236	B2	7/2007	Nathan	2002/0080108	A1	6/2002	Wang
7,264,979	B2	9/2007	Yamagata	2002/0084463	A1	7/2002	Sanford
7,274,345	B2	9/2007	Imamura	2002/0101172	A1	8/2002	Bu
7,274,363	B2	9/2007	Ishizuka	2002/0101433	A1	8/2002	McKnight
7,279,711	B1	10/2007	Yamazaki	2002/0113248	A1	8/2002	Yamagata
7,304,621	B2	12/2007	Oomori	2002/0122308	A1	9/2002	Ikeda
7,310,092	B2	12/2007	Imamura	2002/0130686	A1	9/2002	Forbes
7,315,295	B2	1/2008	Kimura	2002/0154084	A1	10/2002	Tanaka
7,317,429	B2	1/2008	Shirasaki	2002/0158823	A1	10/2002	Zavracky
7,319,465	B2	1/2008	Mikami	2002/0163314	A1	11/2002	Yamazaki
7,321,348	B2	1/2008	Cok	2002/0167471	A1	11/2002	Everitt
7,339,636	B2	3/2008	Voloschenko	2002/0180369	A1	12/2002	Koyama
7,355,574	B1	4/2008	Leon	2002/0180721	A1	12/2002	Kimura
7,358,941	B2	4/2008	Ono	2002/0186214	A1	12/2002	Siwinski
7,402,467	B1	7/2008	Kadono	2002/0190332	A1	12/2002	Lee
7,414,600	B2	8/2008	Nathan	2002/0190924	A1	12/2002	Asano
7,432,885	B2	10/2008	Asano	2002/0190971	A1	12/2002	Nakamura
7,474,285	B2	1/2009	Kimura	2002/0195967	A1	12/2002	Kim
7,485,478	B2	2/2009	Yamagata	2002/0195968	A1	12/2002	Sanford
7,502,000	B2	3/2009	Yuki	2003/0020413	A1	1/2003	Oomura
7,535,449	B2	5/2009	Miyazawa	2003/0030603	A1	2/2003	Shimoda
7,554,512	B2	6/2009	Steer	2003/0062524	A1	4/2003	Kimura
7,569,849	B2	8/2009	Nathan	2003/0063081	A1	4/2003	Kimura et al.
				2003/0071804	A1	4/2003	Yamazaki
				2003/0071821	A1	4/2003	Sundahl
				2003/0076048	A1	4/2003	Rutherford
				2003/0081158	A1	5/2003	Li

(56)

References Cited

U.S. PATENT DOCUMENTS

2003/0090445 A1 5/2003 Chen
 2003/0090447 A1 5/2003 Kimura
 2003/0090481 A1 5/2003 Kimura
 2003/0095087 A1 5/2003 Libsch
 2003/0107560 A1 6/2003 Yumoto
 2003/0111966 A1 6/2003 Mikami
 2003/0122745 A1 7/2003 Miyazawa
 2003/0140958 A1 7/2003 Yang
 2003/0151569 A1 8/2003 Lee
 2003/0169219 A1 9/2003 LeChevalier
 2003/0174152 A1 9/2003 Noguchi
 2003/0178617 A1 9/2003 Appenzeller
 2003/0179626 A1 9/2003 Sanford
 2003/0197663 A1 10/2003 Lee
 2003/0206060 A1 11/2003 Suzuki
 2003/0230980 A1 12/2003 Forrest
 2004/0027063 A1 2/2004 Nishikawa
 2004/0056604 A1 3/2004 Shih
 2004/0066357 A1 4/2004 Kawasaki
 2004/0070557 A1 4/2004 Asano
 2004/0080262 A1 4/2004 Park
 2004/0080470 A1 4/2004 Yamazaki
 2004/0090400 A1 5/2004 Yoo
 2004/0108518 A1 6/2004 Jo
 2004/0113903 A1 6/2004 Mikami
 2004/0129933 A1 7/2004 Nathan
 2004/0130516 A1 7/2004 Nathan
 2004/0135749 A1 7/2004 Kondakov
 2004/0145547 A1 7/2004 Oh
 2004/0150592 A1 8/2004 Mizukoshi
 2004/0150594 A1 8/2004 Koyama
 2004/0150595 A1 8/2004 Kasai
 2004/0155841 A1 8/2004 Kasai
 2004/0174347 A1 9/2004 Sun
 2004/0174349 A1 9/2004 Libsch
 2004/0183759 A1 9/2004 Stevenson
 2004/0189627 A1 9/2004 Shirasaki
 2004/0196275 A1 10/2004 Hattori
 2004/0201554 A1 10/2004 Satoh
 2004/0207615 A1 10/2004 Yumoto
 2004/0233125 A1 11/2004 Tanghe
 2004/0239596 A1 12/2004 Ono
 2004/0252089 A1 12/2004 Ono
 2004/0257355 A1 12/2004 Naugler
 2004/0263437 A1 12/2004 Hattori
 2005/0007357 A1 1/2005 Yamashita
 2005/0030267 A1 2/2005 Tanghe
 2005/0035709 A1 2/2005 Furuie
 2005/0067970 A1 3/2005 Libsch
 2005/0067971 A1 3/2005 Kane
 2005/0068270 A1 3/2005 Awakura
 2005/0088085 A1 4/2005 Nishikawa
 2005/0088103 A1 4/2005 Kageyama
 2005/0105031 A1 5/2005 Shih
 2005/0110420 A1 5/2005 Arnold
 2005/0117096 A1 6/2005 Voloschenko
 2005/0140276 A1* 6/2005 Park H01L 27/322
 313/504
 2005/0140598 A1 6/2005 Kim
 2005/0140610 A1 6/2005 Smith
 2005/0145891 A1 7/2005 Abe
 2005/0156831 A1 7/2005 Yamazaki
 2005/0168416 A1 8/2005 Hashimoto
 2005/0183764 A1* 8/2005 Han B82Y 10/00
 136/251
 2005/0206590 A1 9/2005 Sasaki
 2005/0225686 A1 10/2005 Brummack
 2005/0260777 A1 11/2005 Brabec
 2005/0269959 A1 12/2005 Uchino
 2005/0269960 A1 12/2005 Ono
 2005/0285822 A1 12/2005 Reddy
 2005/0285825 A1 12/2005 Eom
 2006/0007072 A1 1/2006 Choi
 2006/0012310 A1 1/2006 Chen
 2006/0027807 A1 2/2006 Nathan

2006/0030084 A1 2/2006 Young
 2006/0038758 A1 2/2006 Routley
 2006/0044227 A1 3/2006 Hadcock
 2006/0066527 A1 3/2006 Chou
 2006/0092185 A1 5/2006 Jo
 2006/0232522 A1 10/2006 Roy
 2006/0261841 A1 11/2006 Fish
 2006/0264143 A1 11/2006 Lee
 2006/0273997 A1 12/2006 Nathan
 2006/0284801 A1 12/2006 Yoon
 2007/0001937 A1 1/2007 Park
 2007/0001939 A1 1/2007 Hashimoto
 2007/0008268 A1 1/2007 Park
 2007/0008297 A1 1/2007 Bassetti
 2007/0046195 A1 3/2007 Chin
 2007/0069998 A1 3/2007 Naugler
 2007/0080905 A1 4/2007 Takahara
 2007/0080906 A1 4/2007 Tanabe
 2007/0080908 A1 4/2007 Nathan
 2007/0080918 A1 4/2007 Kawachi
 2007/0103419 A1 5/2007 Uchino
 2007/0182671 A1 8/2007 Nathan
 2007/0273294 A1 11/2007 Nagayama
 2007/0285359 A1 12/2007 Ono
 2007/0296672 A1 12/2007 Kim
 2008/0012835 A1 1/2008 Rimon
 2008/0042948 A1 2/2008 Yamashita
 2008/0055209 A1 3/2008 Cok
 2008/0074413 A1 3/2008 Ogura
 2008/0088549 A1 4/2008 Nathan
 2008/0122803 A1 5/2008 Izadi
 2008/0230118 A1* 9/2008 Nakatani B41C 1/14
 136/255
 2009/0032807 A1 2/2009 Shinohara
 2009/0051283 A1 2/2009 Cok
 2009/0160743 A1 6/2009 Tomida
 2009/0162961 A1 6/2009 Deane
 2009/0174628 A1 7/2009 Wang
 2009/0213046 A1 8/2009 Nam
 2010/0052524 A1 3/2010 Kinoshita
 2010/0078230 A1 4/2010 Rosenblatt
 2010/0079711 A1 4/2010 Tanaka
 2010/0097335 A1 4/2010 Jung
 2010/0133994 A1 6/2010 Song
 2010/0134456 A1* 6/2010 Oyamada B82Y 10/00
 345/207
 2010/0140600 A1 6/2010 Clough
 2010/0156279 A1 6/2010 Tamura
 2010/0231528 A1* 9/2010 Wolfe G06F 3/0412
 345/173
 2010/0237374 A1 9/2010 Chu
 2010/0328294 A1 12/2010 Sasaki
 2011/0090210 A1 4/2011 Sasaki
 2011/0133636 A1 6/2011 Matsuo
 2011/0148801 A1 6/2011 Bateman
 2011/0180825 A1 7/2011 Lee
 2012/0212468 A1 8/2012 Govil
 2013/0009930 A1 1/2013 Cho
 2013/0032831 A1 2/2013 Chaji
 2013/0105930 A1* 5/2013 Zhang H01L 31/02168
 257/437
 2013/0113785 A1 5/2013 Sumi
 2014/0225938 A1 8/2014 Soni
 2016/0104751 A1* 4/2016 Sagardoyburu G02F 1/13306
 349/98
 2016/0283012 A1* 9/2016 Long G06F 3/0412

FOREIGN PATENT DOCUMENTS

CA 2 249 592 7/1998
 CA 2 368 386 9/1999
 CA 2 242 720 1/2000
 CA 2 354 018 6/2000
 CA 2 436 451 8/2002
 CA 2 438 577 8/2002
 CA 2 483 645 12/2003
 CA 2 463 653 1/2004
 CA 2498136 3/2004

(56)

References Cited

FOREIGN PATENT DOCUMENTS

CA	2522396	11/2004
CA	2443206	3/2005
CA	2472671	12/2005
CA	2567076	1/2006
CA	2526436	2/2006
CA	2526782	4/2006
CN	1381032	11/2002
CN	1448908	10/2003
CN	1776922	5/2006
CN	101032027 A	9/2007
CN	101118923 A	2/2008
CN	101256293 A	9/2008
CN	101727237 A	6/2010
CN	102113039 A	6/2011
CN	102799331 A	11/2012
CN	102955600 A	3/2013
DE	20 2006 00542	6/2006
EP	0 940 796	9/1999
EP	1 028 471 A	8/2000
EP	1 103 947	5/2001
EP	1 130 565 A1	9/2001
EP	1 184 833	3/2002
EP	1 194 013	4/2002
EP	1 310 939	5/2003
EP	1 335 430 A1	8/2003
EP	1 372 136	12/2003
EP	1 381 019	1/2004
EP	1 418 566	5/2004
EP	1 429 312 A	6/2004
EP	1 439 520	7/2004
EP	1 465 143 A	10/2004
EP	1 467 408	10/2004
EP	1 517 290	3/2005
EP	1 521 203 A2	4/2005
EP	2317499	5/2011
GB	2 205 431	12/1988
JP	09 090405	4/1997
JP	10-153759	6/1998
JP	10-254410	9/1998
JP	11 231805	8/1999
JP	11-282419	10/1999
JP	2000/056847	2/2000
JP	2000-077192	3/2000
JP	2000-089198	3/2000
JP	2000-352941	12/2000
JP	2002-91376	3/2002
JP	2002-268576	9/2002
JP	2002-278513	9/2002
JP	2002-333862	11/2002
JP	2003-022035	1/2003
JP	2003-076331	3/2003
JP	2003-150082	5/2003
JP	2003-177709	6/2003
JP	2003-271095	9/2003
JP	2003-308046	10/2003
JP	2005-057217	3/2005
JP	2006065148	3/2006
JP	2009282158	12/2009
TW	485337	5/2002
TW	502233	9/2002
TW	538650	6/2003
TW	569173	1/2004
WO	WO 94/25954	11/1994
WO	WO 99/48079	9/1999
WO	WO 01/27910 A1	4/2001
WO	WO 02/067327 A	8/2002
WO	WO 03/034389 A	4/2003
WO	WO 03/063124	7/2003
WO	WO 03/077231	9/2003
WO	WO 03/105117	12/2003
WO	WO 2004/003877	1/2004
WO	WO 2004/034364	4/2004
WO	WO 2005/022498	3/2005
WO	WO 2005/029455	3/2005
WO	WO 2005/034072	4/2005

WO	WO 2005/055185	6/2005
WO	WO 2006/053424	5/2006
WO	WO 2006/063448 A	6/2006
WO	WO 2006/137337	12/2006
WO	WO 2007/003877 A	1/2007
WO	WO 2007/079572	7/2007
WO	WO 2010/023270	3/2010

OTHER PUBLICATIONS

- Alexander et al.: "Pixel circuits and drive schemes for glass and elastic AMOLED displays"; dated Jul. 2005 (9 pages).
- Alexander et al.: "Unique Electrical Measurement Technology for Compensation, Inspection, and Process Diagnostics of AMOLED HDTV"; dated May 2010 (4 pages).
- Ashtiani et al.: "AMOLED Pixel Circuit With Electronic Compensation of Luminance Degradation"; dated Mar. 2007 (4 pages).
- Chaji et al.: "A Current-Mode Comparator for Digital Calibration of Amorphous Silicon AMOLED Displays"; dated Jul. 2008 (5 pages).
- Chaji et al.: "A fast settling current driver based on the CCII for AMOLED displays"; dated Dec. 2009 (6 pages).
- Chaji et al.: "A Low-Cost Stable Amorphous Silicon AMOLED Display with Full V~T- and V~O~L~E~D Shift Compensation"; dated May 2007 (4 pages).
- Chaji et al.: "A low-power driving scheme for a-Si:H active-matrix organic light-emitting diode displays"; dated Jun. 2005 (4 pages.).
- Chaji et al.: "A low-power high-performance digital circuit for deep submicron technologies"; dated Jun. 2005 (4 pp.).
- Chaji et al.: "A novel a-Si:H Amoled pixel circuit based on short-term stress stability of a-Si:H TFTs"; dated Oct. 2005 (3 pages).
- Chaji et al.: "A Novel Driving Scheme and Pixel Circuit for AMOLED Displays"; dated Jun. 2006 (4 pages).
- Chaji et al.: "A novel driving scheme for high-resolution large-area a-Si:H AMOLED displays"; dated Aug. 2005 (4 pages).
- Chaji et al.: "A Stable Voltage-Programmed Pixel Circuit for a-Si:H AMOLED Displays"; dated Dec. 2006 (12 pages).
- Chaji et al.: "A Sub- μ A fast-settling current-programmed pixel circuit for AMOLED displays"; dated Sep. 2007.
- Chaji et al.: "An Enhanced and Simplified Optical Feedback Pixel Circuit for AMOLED Displays"; dated Oct. 2006.
- Chaji et al.: "Compensation technique for DC and transient instability of thin film transistor circuits for large-area devices"; dated Aug. 2008.
- Chaji et al.: "Driving scheme for stable operation of 2-TFT a-Si AMOLED pixel"; dated Apr. 2005 (2 pages).
- Chaji et al.: "Dynamic-effect compensating technique for stable a-Si:H Amoled displays"; dated Aug. 2005 (4 pages).
- Chaji et al.: "Electrical Compensation of OLED Luminance Degradation"; dated Dec. 2007 (3 pages).
- Chaji et al.: "eUTDSP: a design study of a new VLIW-based DSP architecture"; dated My 2003 (4 pages).
- Chaji et al.: "Fast and Offset-Leakage Insensitive Current-Mode Line Driver for Active Matrix Displays and Sensors"; dated Feb. 2009 (8 pages).
- Chaji et al.: "High Speed Low Power Adder Design With a New Logic Style: Pseudo Dynamic Logic (SDL)"; dated Oct. 2001 (4 pages).
- Chaji et al.: "High-precision, fast current source for large-area current-programmed a-Si flat panels"; dated Sep. 2006 (4 pages).
- Chaji et al.: "Low-Cost AMOLED Television with IGNIS Compensating Technology"; dated May 2008 (4 pages).
- Chaji et al.: "Low-Cost Stable a-Si:H Amoled Display for Portable Applications"; dated Jun. 2006 (4 pages).
- Chaji et al.: "Low-Power Low-Cost Voltage-Programmed a-Si:H AMOLED Display"; dated Jun. 2008 (5 pages).
- Chaji et al.: "Merged phototransistor pixel with enhanced near infrared response and flicker noise reduction for biomolecular imaging"; dated Nov. 2008 (3 pages).
- Chaji et al.: "Parallel Addressing Scheme for Voltage-Programmed Active-Matrix OLED Displays"; dated May 2007 (6 pages).
- Chaji et al.: "Pseudo dynamic logic (SDL): a high-speed and low-power dynamic logic family"; dated 2002 (4 pages).

(56)

References Cited

OTHER PUBLICATIONS

- Chaji et al.: "Stable a-Si:H circuits based on short-term stress stability of amorphous silicon thin film transistors"; dated May 2006 (4 pages).
- Chaji et al.: "Stable Pixel Circuit for Small-Area High-Resolution a-Si:H AMOLED Displays"; dated Oct. 2008 (6 pages)
- Chaji et al.: "Stable RGBW AMOLED display with OLED degradation compensation using electrical feedback"; dated Feb. 2010 (2 pages).
- Chaji et al.: "Thin-Film Transistor Integration for Biomedical Imaging and Amoled Displays"; dated 2008 (177 pages).
- European Search Report and Written Opinion for Application No. 08 86 5338 dated Nov. 2, 2011 (7 pages).
- European Search Report for European Application No. EP 04 78 6661 dated Mar. 9, 2009.
- European Search Report for European Application No. EP 05 75 9141 dated Oct. 30, 2009.
- European Search Report for European Application No. EP 05 82 1114 dated Mar. 27, 2009.
- European Search Report for European Application No. EP 07 71 9579 dated May 20, 2009.
- European Search Report dated Mar. 26, 2012 in corresponding European Patent Application No. 10000421.7 (6 pages).
- Extended European Search Report dated Apr. 27, 2011 issued during prosecution of European patent application No. 09733076.5 (13 pages).
- Goh et al., "A New a-Si:H Thin Film Transistor Pixel Circuit for Active-Matrix Organic Light-Emitting Diodes", IEEE Electron Device Letters, vol. 24, No. 9, Sep. 2003, 4 pages.
- International Search Report for International Application No. PCT/CA02/00180 dated Jul. 31, 2002 (3 pages).
- International Search Report for International Application No. PCT/CA2004/001741 dated Feb. 21, 2005.
- International Search Report for International Application No. PCT/CA2005/001844 dated Mar. 28, 2006 (2 pages).
- International Search Report for International Application No. PCT/CA2005/001007 dated Oct. 18, 2005.
- International Search Report for International Application No. PCT/CA2007/000652 dated Jul. 25, 2007.
- International Search Report for International Application No. PCT/CA2008/002307, dated Apr. 28, 2009 (3 pages).
- International Search Report for International Application No. PCT/IB2011/055135, Canadian Patent Office, dated Apr. 16, 2012 (5 pages).
- International Search Report dated Jul. 30, 2009 for International Application No. PCT/CA2009/000501 (4 pages).
- Jafarabadiashtiani et al.: "A New Driving Method for a-Si AMOLED Displays Based on Voltage Feedback"; dated 2005 (4 pages).
- Lee et al.: "Ambipolar Thin-Film Transistors Fabricated by PECVD Nanocrystalline Silicon"; dated 2006 (6 pages).
- Ma e y et al.: "Organic Light-Emitting Diode/Thin Film Transistor Integration for foldable Displays" Conference record of the 1997 International display research conference and international workshops on LCD technology and emissive technology. Toronto, Sep. 15-19, 1997 (6 pages).
- Matsueda y et al.: "35.1: 2.5-in. AMOLED with Integrated 6-bit Gamma Compensated Digital Data Driver"; dated May 2004.
- Nathan et al.: "Backplane Requirements for Active Matrix Organic Light Emitting Diode Displays"; dated 2006 (16 pages).
- Nathan et al.: "Call for papers second international workshop on compact thin-film transistor (TFT) modeling for circuit simulation"; dated Sep. 2009 (1 page).
- Nathan et al.: "Driving schemes for a-Si and LTPS AMOLED displays"; dated Dec. 2005 (11 pages).
- Nathan et al.: "Invited Paper: a-Si for AMOLED—Meeting the Performance and Cost Demands of Display Applications (Cell Phone to HDTV)"; dated 2006 (4 pages).
- Nathan et al.: "Thin film imaging technology on glass and plastic" ICM 2000, Proceedings of the 12th International Conference on Microelectronics, (IEEE Cat. No. 00EX453), Tehran Iran; dated Oct. 31,-Nov. 2, 2000, pp. 11-14, ISBN: 964-360-057-2, p. 13, col. 1, line-11-48; (4 pages).
- Nathan et al., "Amorphous Silicon Thin Film Transistor Circuit Integration for Organic Led Displays on Glass and Plastic", IEEE Journal of Solid-State Circuits, vol. 39, No. 9, Sep. 2004, pp. 1477-1486.
- Office Action issued in Chinese Patent Application 200910246264.4 dated May 7, 2013; 8 pages.
- Patent Abstracts of Japan, vol. 2000, No. 09, Oct. 13, 2000—JP 2000 172199 A, Jun. 3, 2000, abstract.
- Patent Abstracts of Japan, vol. 2002, No. 03, Apr. 3, 2002 (Apr. 4, 2004 & JP 2001 318627 A (Semiconductor EnergyLab DO LTD), Nov. 16, 2001, abstract, paragraphs '01331-01801, paragraph '01691, paragraph '01701, paragraph '01721 and figure 10.
- Philipp: "Charge transfer sensing" Sensor Review, vol. 19, No. 2, Dec. 31, 1999 (Dec. 31, 1999), 10 pages.
- Rafati et al.: "Comparison of a 17 b multiplier in Dual-rail domino and in Dual-rail D L (D L) logic styles"; dated 2002 (4 pages).
- Safavian et al.: "Three-TFT image sensor for real-time digital X-ray imaging"; dated Feb. 2, 2006 (2 pages).
- Safavian et al.: "3-TFT active pixel sensor with correlated double sampling readout circuit for real-time medical x-ray imaging"; dated Jun. 2006 (4 pages).
- Safavian et al.: "A novel current scaling active pixel sensor with correlated double sampling readout circuit for real time medical x-ray imaging"; dated May 2007 (7 pages).
- Safavian et al.: "A novel hybrid active-passive pixel with correlated double sampling CMOS readout circuit for medical x-ray imaging"; dated May 2008 (4 pages).
- Safavian et al.: "Self-compensated a-Si:H detector with current-mode readout circuit for digital X-ray fluoroscopy"; dated Aug. 2005 (4 pages).
- Safavian et al.: "TFT active image sensor with current-mode readout circuit for digital x-ray fluoroscopy"; dated Sep. 2005 (9 pages).
- Sanford, James L., et al., "4.2 TFT AMOLED Pixel Circuits and Driving Methods", SID 03 Digest, ISSN/0003, 2003, pp. 10-13.
- Stewart M. et al., "Polysilicon TFT technology for active matrix OLED displays" IEEE transactions on electron devices, vol. 48, No. 5; Dated May, 2001 (7 pages).
- Tatsuya Sasaoka et al., 24.4L; Late-News Paper: A 13.0-inch AM-OLED Display with Top Emitting Structure and Adaptive Current Mode Programmed Pixel Circuit (TAC), SID 01 Digest, (2001), pp. 384-387.
- Vygranenko et al.: "Stability of indium-oxide thin-film transistors by reactive ion beam assisted deposition"; dated 2009.
- Wang et al.: "Indium oxides by reactive ion beam assisted evaporation: From material study to device application"; dated Mar. 2009 (6 pages).
- Written Opinion dated Jul. 30, 2009 for International Application No. PCT/CA2009/000501 (6 pages).
- Yi He et al., "Current-Source a-Si:H Thin Film Transistor Circuit for Active-Matrix Organic Light-Emitting Displays", IEEE Electron Device Letters, vol. 21, No. 12, Dec., 2000, pp. 590-592.
- Zhiguo Meng et al.; "24.3: Active-Matrix Organic Light-Emitting Diode Display implemented Using Metal-Induced Unilaterally Crystallized Polycrystalline Silicon Thin-Film Transistors", SID 01 Digest, (2001), pp. 380-383.
- International Search Report for Application No. PCT/IB2014/059409, Canadian Intellectual Property Office, dated Jun. 12, 2014 (4 pages).
- Written Opinion for Application No. PCT/IB2014/059409, Canadian Intellectual Property Office, dated Jun. 12, 2014 (4 pages).
- Extended European Search Report for Application No. EP 14181848, 4, dated Mar. 5, 2015, (9 pages).
- Extended European Search Report for Application No. EP 16192749, 6, dated Dec. 15, 2016 (16 pages).

* cited by examiner

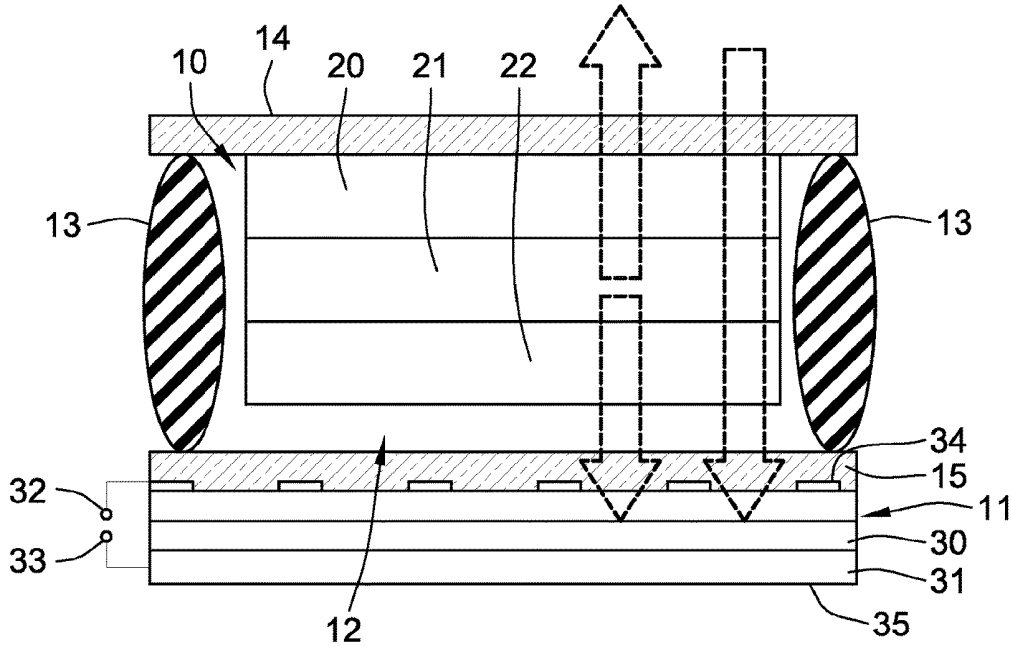

FIG. 1

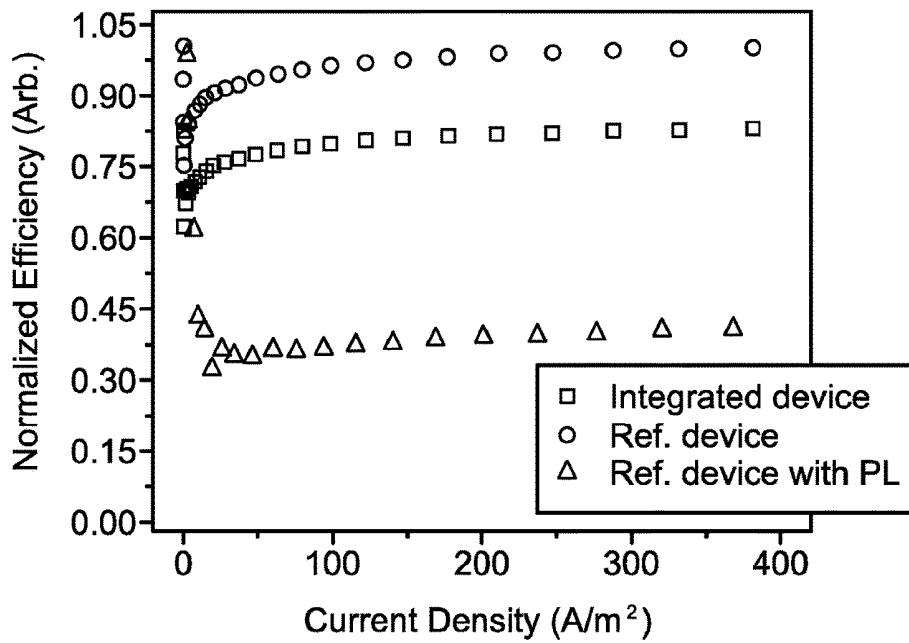

FIG. 2

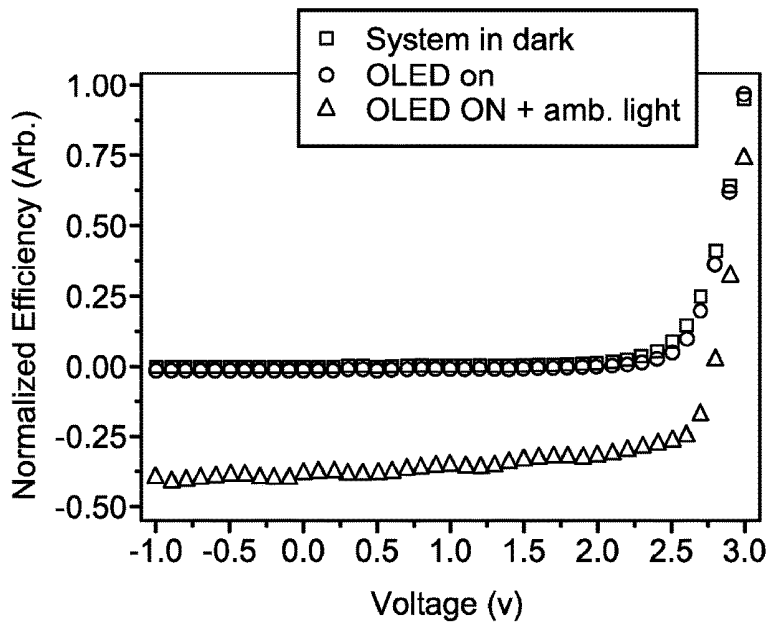

FIG. 3

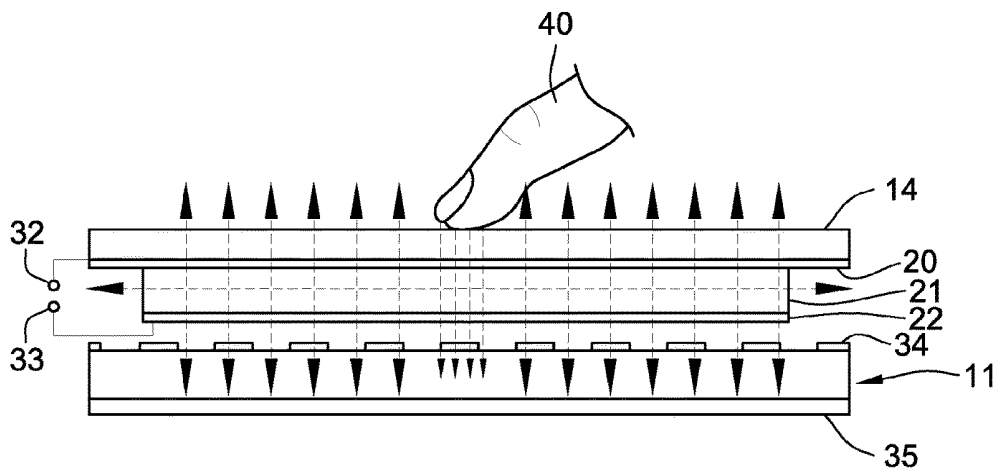

FIG. 4

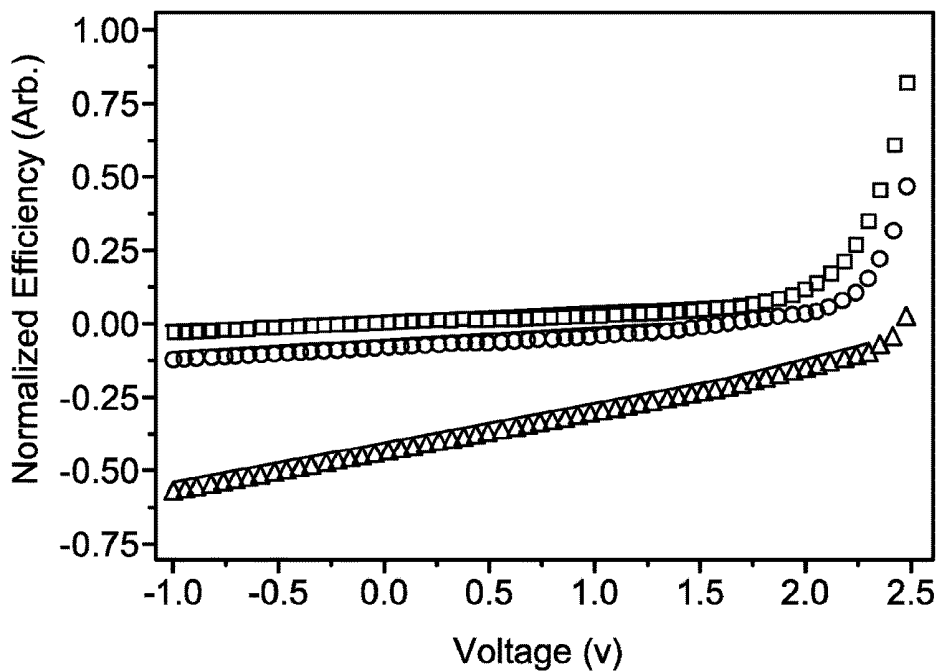

FIG. 5

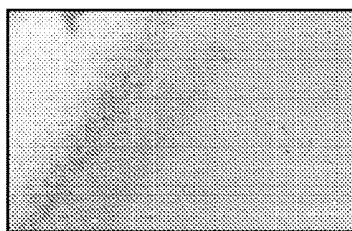

FIG. 6A

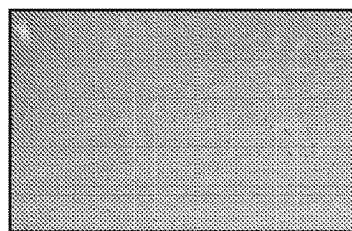

FIG. 6B

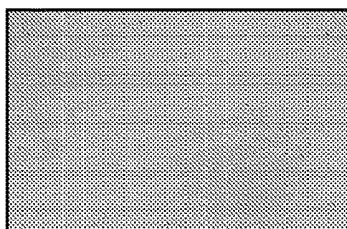

FIG. 6C

MULTI-FUNCTIONAL ACTIVE MATRIX ORGANIC LIGHT-EMITTING DIODE DISPLAY

CROSS-REFERENCE TO RELATED APPLICATIONS

This application is a continuation of U.S. patent application Ser. No. 15/783,662, filed Oct. 13, 2017, now allowed, which is a continuation of U.S. patent application Ser. No. 15/174,174, filed Jun. 6, 2016, now U.S. Pat. No. 9,818,806, which is a continuation of U.S. patent application Ser. No. 13/689,241, filed Nov. 29, 2012, now U.S. Pat. No. 9,385,169, which claims priority to U.S. Provisional Application No. 61/564,634 filed Nov. 29, 2011, each of which is hereby incorporated by reference herein in its entirety.

FIELD OF THE INVENTION

The present invention relates generally to active matrix displays organic light-emitting diode (AMOLED) displays and, more particularly, to multi-functional AMOLED displays having integrated solar cells.

BACKGROUND OF THE INVENTION

Organic light-emitting diodes (OLEDs) have attracted significant attention because of their great potential for making next-generation flat panel displays, i.e., active-matrix organic light-emitting diode displays (AMOLEDs). The standard OLEDs consist of a transparent electrode, organic layers and a metallic reflective electrode, which experience a strong ambient light reflection and a reduced contrast of displays operating under sunlight, mandating a circular polarizer. Other approaches, such as black cathodes, have been proposed. However, all these designs absorb and waste the incident ambient light and a significant amount of light emitted by the OLEDs. In addition, AMOLEDs today are typically integrated with a touch panel in front of the AMOLED in many applications such as cellular phones, personal digital assistants (PDAs), computer displays and touch tablets. The light output from the OLEDs is further reduced by the touch panel. Altogether, the AMOLED display system is complex and costly, and exhibits relatively low efficiency and wastes a large amount of energy.

SUMMARY OF THE INVENTION

In accordance with one embodiment, a multi-functional active matrix display comprises a transparent front sheet, a semi-transparent layer of light emissive devices adjacent the rear side of the front sheet and forming a matrix of display pixels, and a solar cell layer located behind the light emissive devices for converting both ambient light and internal light from the light emissive devices into electrical energy, the solar cell layer including an array of electrodes on the front surface of the solar cell layer for use in detecting the location of a change in the amount of light impinging on a portion of the front surface of the solar cell layer.

In one implementation, the semi-transparent layer of light emissive devices includes a substantially transparent anode adjacent the transparent front sheet, a semi-transparent semiconductor stack forming organic light emitting diodes adjacent the rear side of the anode, and a semi-transparent cathode adjacent the rear side of the semiconductor stack. A cover glass is spaced rearwardly of the cathode, covering the solar cell layer, and a peripheral sealant bonds the cover

glass to the front sheet. The peripheral sealant holds the cover sheet spaced away from the rear side of said cathode to form an air gap between the cathode and said the sheet.

This integration of the semi-transparent OLED panel and the solar panel offers ease of fabrication and low cost while providing advantages of multi-functionality such as low ambient light reflection, low power consumption, high yield and optical touch screen functionality. Specifically, the integrated device permits the touching of portions of the front surface of an active matrix OLED display to be sensed by using the solar panel to produce an electrical output signal corresponding to light that passes through said OLED display, including light reflected from an object touching the front surface of said OLED display. Then the location of the touching object can be determined by monitoring and analyzing the electrical output signals produced by said solar panel, using conventional touch-screen circuitry.

With this design, the incident ambient light and the portion of light emitted through the transparent electrode is absorbed by the back solar cell instead of being reflected, resulting in improved contrast in the displayed image. Moreover, in contrast with the polarizer and black cathode approaches, the absorbed light is recycled as useful electrical power or touch feedback instead of being converted to heat. At the same time, the display system can be manufactured with high yields by using independent panel and solar cell processes. Since the polarizer used in AMOLED displays typically has only about 43% transmittance, displays lose 57% of their electroluminescence by using the polarizer.

Using the display system itself as an optical-based touch screen, without extra IR-LEDs and sensors, reduces the device complexity and fabrication cost of the display system by eliminating the need for extra IR-LEDs and sensors. The solar cell can also be used for initial uniformity calibration of the display, e.g., for correcting non-uniformities of an active matrix OLED display by (a) integrating the OLED display with a solar panel that produces an electrical output signal corresponding to light emissions from the OLED display, (b) detecting non-uniformities in the OLED display from said output signal, and (c) correcting the detected non-uniformities in the OLED display.

This display system has a simple structure that exhibits superior contrast without sacrificing electroluminescence, a high power efficiency by recycling OLED internal emissions as well as incident ambient light, and touch screen functionality.

BRIEF DESCRIPTION OF THE DRAWINGS

The foregoing and other advantages of the present disclosure will become apparent upon reading the following detailed description and upon reference to the drawings.

FIG. 1 is diagrammatic side elevation of an active matrix display that includes integrated solar cell and semi-transparent OLED layers.

FIG. 2 is a plot of current efficiency vs. current density for the integrated device of FIG. 1 and a reference device.

FIG. 3 is a plot of current efficiency vs. voltage for the integrated device of FIG. 1 with the solar cell in a dark environment, under illumination of the OLED layer, and under illumination of both the OLED layer and ambient light.

FIG. 4 is a diagrammatic illustration of the integrated device of FIG. 1 operating as an optical-based touch screen.

FIG. 5 is a plot of current efficiency vs. voltage for the integrated device of FIG. 1 with the solar cell in a dark environment, under illumination of the OLED layer with and without touch.

FIG. 6A is an image of an AMOLED panel without compensation.

FIG. 6B is an image of an AMOLED panel with in-pixel compensation.

FIG. 6C is an image of an AMOLED panel with extra external calibration.

DETAILED DESCRIPTION OF THE ILLUSTRATED EMBODIMENTS

Although the invention will be described in connection with certain aspects and/or embodiments, it will be understood that the invention is not limited to those particular aspects and/or embodiments. On the contrary, the invention is intended to cover all alternatives, modifications, and equivalent arrangements as may be included within the spirit and scope of the invention as defined by the appended claims.

FIG. 1 illustrates a display system that includes a semitransparent OLED layer 10 integrated with a solar panel 11 separated from the OLED layer 10 by an air gap 12. The OLED layer 10 includes multiple pixels arranged in an X-Y matrix that is combined with programming, driving and control lines connected to the different rows and columns of the pixels. A peripheral sealant 13 (e.g., epoxy) holds the two layers 10 and 11 in the desired positions relative to each other. The OLED layer 10 has a glass substrate 14, the solar panel 11 has a glass cover 15, and the sealant 13 is bonded to the opposed surfaces of the substrate 14 and the cover 15 to form an integrated structure.

The OLED layer 10 includes a substantially transparent anode 20, e.g., indium-tin-oxide (ITO), adjacent the glass substrate 14, an organic semiconductor stack 21 engaging the rear surface of the anode 20, and a cathode 22 engaging the rear surface of the stack 21. The cathode 22 is made of a transparent or semi-transparent material, e.g., thin silver (Ag), to allow light to pass through the OLED layer 10 to the solar panel 11. (The anode 20 and the semiconductor stack 21 in OLEDs are typically at least semi-transparent, but the cathode in previous OLEDs has often been opaque and sometimes even light-absorbing to minimize the reflection of ambient light from the OLED.)

Light that passes rearwardly through the OLED layer 10, as illustrated by the right-hand arrow in FIG. 1, continues on through the air gap 12 and the cover glass cover 15 of the solar cell 11 to the junction between n-type and p-type semiconductor layers 30 and 31 in the solar cell. Optical energy passing through the glass cover 15 is converted to electrical energy by the semiconductor layers 30 and 31, producing an output voltage across a pair of output terminals 32 and 33. The various materials that can be used in the layers 30 and 31 to convert light to electrical energy, as well as the material dimensions, are well known in the solar cell industry. The positive output terminal 32 is connected to the n-type semiconductor layer 30 (e.g., copper phthalocyanine) by front electrodes 34 attached to the front surface of the layer 30. The negative output terminal 33 is connected to the p-type semiconductor layer 31 (e.g., 3,4,9,10-perylene-tetracarboxylic bis-benzimidazole) by rear electrodes 35 attached to the rear surface of the layer 31.

One or more switches may be connected to the terminals 32 and 33 to permit the solar panel 11 to be controllably connected to either (1) an electrical energy storage device

such as a rechargeable battery or one or more capacitors, or (2) to a system that uses the solar panel 11 as a touch screen, to detect when and where the front of the display is "touched" by a user.

In the illustrative embodiment of FIG. 1, the solar panel 11 is used to form part of the encapsulation of the OLED layer 10 by forming the rear wall of the encapsulation for the entire display. Specifically, the cover glass 15 of the solar cell array forms the rear wall of the encapsulation for the OLED layer 10, the single glass substrate 14 forms the front wall, and the perimeter sealant 13 forms the side walls.

One example of a suitable semitransparent OLED layer 10 includes the following materials:

Anode 20

ITO (100 nm)

Semiconductor Stack 21

hole transport layer—N,N'-bis(naphthalen-1-yl)-N,N'-bis(phenyl)benzidine (NBP) (70 nm)

emitter layer—tris(8-hydroxyquinoline) aluminum (Alq₃): 10-(2-benzothiazolyl)-1,1,7,7-tetramethyl-2,3,6,7-tetrahydro-1H, 5H, 11H, [1] benzo-pyrano [6,7,8-ij] quinolizin-11-one (C545T) (99%:1%) (30 nm)

electron transport layer—Alq₃ (40 nm)

electron injection layer—4,7-diphenyl-1,10-phenanthroline (Bphen): (Cs₂CO₃) (9:1) (10 nm)

Semitransparent Cathode 22—

MoO₃:NPB(1:1) (20 nm)

Ag (14 nm)

MoO₃:NPB(1:1) (20 nm)

The performance of the above OLED layer in an integrated device using a commercial solar panel was compared with a reference device, which was an OLED with exactly the same semiconductor stack and a metallic cathode (Mg/Ag). The reflectance of the reference device was very high, due to the reflection of the metallic electrode; in contrast, the reflectance of the integrated device is very low. The reflectance of the integrated device with the transparent electrode was much lower than the reflectances of both the reference device (with the metallic electrode) and the reference device equipped with a circular polarizer.

The current efficiency-current density characteristics of the integrated device with the transparent electrode and the reference device are shown in FIG. 2. At a current density of 200 A/m², the integrated device with the transparent electrode had a current efficiency of 5.88 cd/A, which was 82.8% of the current efficiency (7.1 cd/A) of the reference device. The current efficiency of the reference device with a circular polarizer was only 60% of the current efficiency of the reference device. The integrated device converts both the incident ambient light and a portion of the OLED internal luminance into useful electrical energy instead of being wasted.

For both the integrated device and the reference device described above, all materials were deposited sequentially at a rate of 1-3 Å/s using vacuum thermal evaporation at a pressure below 5×10⁻⁶ Torr on ITO-coated glass substrates. The substrates were cleaned with acetone and isopropyl alcohol, dried in an oven, and finally cleaned by UV ozone treatment before use. In the integrated device, the solar panel was a commercial Sanyo Energy AM-1456CA amorphous silicon solar cell with a short circuit current of 6 μA and a voltage output of 2.4V. The integrated device was fabricated using the custom cut solar cell as encapsulation glass for the OLED layer.

The optical reflectance of the device was measured by using a Shimadzu UV-2501PC UV-Visible spectrophotometer. The current density (J)-luminance (L)-voltage (V)

characteristics of the device was measured with an Agilent 4155C semiconductor parameter analyzer and a silicon photodiode pre-calibrated by a Minolta Chromameter. The ambient light was room light, and the tests were carried out at room temperature. The performances of the fabricated devices were compared with each other and with the reference device equipped with a circular polarizer.

FIG. 3 shows current-voltage (I-V) characteristics of the solar panel (1) in dark, (20 under the illumination of OLED, and (3) under illumination of both ambient light and the OLED at 20 mA/cm². The dark current of the solar cell shows a nice diode characteristic. When the solar cell is under the illumination of the OLED under 20 mA/cm² current density, the solar cell shows a short circuit current (I_{sc}) of $-0.16 \mu\text{A}$, an open circuit voltage (V_{oc}) of 1.6V, and a filling factor (FF) of 0.31. The maximum converted electrical power is 0.08 μW , which demonstrates that the integrated device is capable of recycling a portion of the internal OLED luminescence energy. When the solar cell is under the illumination of both ambient light and the overlying OLED, the solar cell shows a short circuit current (I_{sc}) of $-7.63 \mu\text{A}$, an open circuit voltage (V_{oc}) of 2.79V, and a filling factor (FF) of 0.65. The maximum converted electrical power is 13.8 μW in this case. The increased electrical power comes from the incident ambient light.

Overall, the integrated device shows a higher current efficiency than the reference device with a circular polarizer, and further recycles the energy of the incident ambient light and the internal luminance of the top OLED, which demonstrates a significant low power consumption display system.

Conventional touch displays stack a touch panel on top of an LCD or AMOLED display. The touch panel reduces the luminance output of the display beneath the touch panel and adds extra cost to the fabrication. The integrated device described above is capable of functioning as an optical-based touch screen without any extra panels or cost. Unlike previous optical-based touch screens which require extra IR-LEDs and sensors, the integrated device described here utilizes the internal illumination from the top OLED as an optical signal, and the solar cell is utilized as an optical sensor. Since the OLED has very good luminance uniformity, the emitted light is evenly spread across the device surface as well as the surface of the solar panel. When the front surface of the display is touched by a finger or other object, a portion of the emitted light is reflected off the object back into the device and onto the solar panel, which changes the electrical output of the solar panel. The system is able to detect this change in the electrical output, thereby detecting the touch. The benefit of this optical-based touch system is that it works for any object (dry finger, wet finger, gloved finger, stylus, pen, etc.), because detection of the touch is based on the optical reflection rather than a change in the refractive index, capacitance or resistance of the touch panel.

FIG. 4 is a diagrammatic illustration of the integrated device of FIG. 1 being used as a touch screen. To allow the solar cell to convert a significant amount of light that impinges on the front of the cell, the front electrodes 34 are spaced apart to leave a large amount of open area through which impinging light can pass to the front semiconductor layer 30. The illustrative electrode pattern in FIG. 4 has all the front electrodes 34 extending in the X direction, and all the back contacts 35 extending in the Y direction. Alternatively, one electrode can be patterned in both directions. An additional option is the addition of tall wall traces covered with metal so that they can be connected to the OLED

transparent electrode to further reduce the resistance. Another option is to fill the gap 12 between the OLED layer 10 and the cover glass 15 with a transparent material that acts as an optical glue, for better light transmittance.

When the front of the display is touched or obstructed by a finger 40 (FIG. 4) or other object that reflects or otherwise changes the amount of light impinging on the solar panel at a particular location, the resulting change in the electrical output of the solar panel can be detected. The electrodes 34 and 35 are all individually connected to a touch screen controller circuit that monitors the current levels in the individual electrodes, and/or the voltage levels across different pairs of electrodes, and analyzes the location responsible for each change in those current and/or voltage levels. Touch screen controller circuits are well known in the touch-screen industry, and are capable of quickly and accurately reading the exact position of a "touch" that causes a change in the electrode currents and/or voltages being monitored. The touch screen circuits may be active whenever the display is active, or a proximity switch can be used to activate the touch screen circuits only when the front surface of the display is touched.

The solar panel may also be used for imaging, as well as a touch screen. An algorithm may be used to capture multiple images, using different pixels of the display to provide different levels of brightness for compressive sensing.

FIG. 5 is a plot of normalized current I_{sc} vs. voltage V_{oc} characteristics of the solar panel under the illumination of the overlying OLED layer, with and without touch. When the front of the integrated device is touched, I_{sc} and V_{oc} of the solar cell change from $-0.16 \mu\text{A}$ to $-0.87 \mu\text{A}$ and 1.6 V to 2.46 V, respectively, which allows the system to detect the touch. Since this technology is based on the contrast between the illuminating background and the light reflected by a fingertip, for example, the ambient light has an influence on the touch sensitivity of the system. The changes in I_{sc} or V_{oc} in FIG. 5 are relatively small, but by improving the solar cell efficiency and controlling the amount of background luminance by changing the thickness of the semitransparent cathode of the OLED, the contrast can be further improved. In general, a thinner semitransparent OLED cathode will benefit the luminance efficiency and lower the ambient light reflectance; however, it has a negative influence on the contrast of the touch screen.

In a modified embodiment, the solar panel is calibrated with different OLED and/or ambient brightness levels, and the values are stored in a lookup table (LUT). Touching the surface of the display changes the optical behavior of the stacked structure, and an expected value for each cell can be fetched from the LUT based on the OLED luminance and the ambient light. The output voltage or current from the solar cells can then be read, and a profile created based on differences between expected values and measured values. A predefined library or dictionary can be used to translate the created profile to different gestures or touch functions.

In another modified embodiment, each solar cell unit represents a pixel or sub-pixel, and the solar cells are calibrated as smaller units (pixel resolution) with light sources at different colors. Each solar cell unit may represent a cluster of pixels or sub-pixels. The solar cells are calibrated as smaller units (pixel resolution) with reference light sources at different color and brightness levels, and the values stored in LUTs or used to make functions. The calibration measurements can be repeated during the display lifetime by the user or at defined intervals based on the usage of the display. Calibrating the input video signals with the

values stored in the LUTs can compensate for non-uniformity and aging. Different gray scales may be applied while measuring the values of each solar cell unit, and storing the values in a LUT.

Each solar cell unit can represent a pixel or sub-pixel. The solar cell can be calibrated as smaller units (pixel resolution) with reference light sources at different colors and brightness levels and the values stored in LUTs or used to make functions. Different gray scales may be applied while measuring the values of each solar cell unit, and then calibrating the input video signals with the values stored in the LUTs to compensate for non-uniformity and aging. The calibration measurements can be repeated during the display lifetime by the user or at defined intervals based on the usage of the display.

Alternatively, each solar cell unit can represent a pixel or sub-pixel, calibrated as smaller units (pixel resolution) with reference light sources at different colors and brightness levels with the values being stored in LUTs or used to make functions, and then applying different patterns (e.g., created as described in U.S. Patent Application Publication No. 2011/0227964, which is incorporated by reference in its entirety herein) to each cluster and measuring the values of each solar cell unit. The functions and methods described in U.S. Patent Application Publication No. 2011/0227964 may be used to extract the non-uniformities/aging for each pixel in the clusters, with the resulting values being stored in a LUT. The input video signals may then be calibrated with the values stored in LUTs to compensate for non-uniformity and aging. The measurements can be repeated during the display lifetime either by the user or at defined intervals based on display usage.

The solar panel can also be used for initial uniformity calibration of the display. One of the major problems with OLED panels is non-uniformity. Common sources of non-uniformity are the manufacturing process and differential aging during use. While in-pixel compensation can improve the uniformity of a display, the limited compensation level attainable with this technique is not sufficient for some displays, thereby reducing the yield. With the integrated OLED/solar panel, the output current of the solar panel can be used to detect and correct non-uniformities in the display. Specifically, calibrated imaging can be used to determine the luminance of each pixel at various levels. The theory has also been tested on an AMOLED display, and FIG. 6 shows uniformity images of an AMOLED panel (a) without compensation, (b) with in-pixel compensation and (c) with extra external compensation. FIG. 6(c) highlights the effect of external compensation which increases the yield to a significantly higher level (some ripples are due to the interference between camera and display spatial resolution). Here the solar panel was calibrated with an external source first and then the panel was calibrated with the results extracted from the panel.

As can be seen from the foregoing description, the integrated display can be used to provide AMOLED displays with a low ambient light reflectance without employing any extra layers (polarizer), low power consumption with recycled electrical energy, and functionality as an optical based touch screen without an extra touch panel, LED sources or sensors. Moreover, the output of the solar panel can be used to detect and correct the non-uniformity of the OLED panel. By carefully choosing the solar cell and adjusting the semitransparent cathode of the OLED, the performance of this display system can be greatly improved.

While particular implementations and applications of the present disclosure have been illustrated and described, it is

to be understood that the present disclosure is not limited to the precise construction and compositions disclosed herein and that various modifications, changes, and variations can be apparent from the foregoing descriptions without departing from the spirit and scope of the invention as defined in the appended claims.

What is claimed is:

1. A method of managing light emitted from an active matrix OLED display, the method comprising:
 - emitting light from the OLED display;
 - receiving at least a portion of the light emitted from the OLED display at a solar panel adjacent the OLED display; and
 - converting at the solar panel the at least a portion of the light received by the solar panel into an electrical output.
2. The method of claim 1 further comprising:
 - prior to emitting light from the OLED display, integrating behind the OLED display, the solar panel with the OLED display.
3. The method of claim 1, in which the electrical output comprises electrical energy, the method further comprising:
 - storing the electrical energy in electrical energy storage coupled to the solar panel.
4. The method of claim 3, further comprising:
 - receiving ambient light at the solar panel; and
 - converting at the solar panel the ambient light into electrical energy for storage in the electrical energy storage.
5. The method of claim 1, in which the solar panel includes an array of electrodes on at least one surface of the solar panel for generating the electrical output, the electrical output corresponding to light emissions from various areas across the OLED display, the method further comprising:
 - detecting non-uniformities in the OLED display from the electrical output; and
 - correcting for the detected non-uniformities in the OLED display.
6. The method of claim 1, in which the at least a portion of the light includes light emitted by the OLED display and reflected from an object touching the front surface of the OLED display, the method further comprising:
 - detecting the location of the touching object from the electrical output produced by the solar panel.
7. An active matrix display comprising:
 - a semi-transparent layer of light emissive devices forming a matrix of display pixels for displaying images; and
 - a solar panel adjacent said semi-transparent layer for receiving at least a portion of the light emitted from the semi-transparent layer and converting the at least a portion of the light into an electrical output.
8. The active matrix display of claim 7 further comprising:
 - a transparent front sheet adjacent a front side of the semi-transparent layer, the displayed images for viewing through the front sheet.
9. The active matrix display of claim 8 in which the semi-transparent layer of light emissive devices includes a substantially transparent anode adjacent the front sheet, a semi-transparent semiconductor stack forming organic light emitting diodes adjacent the rear side of the anode, a semi-transparent cathode adjacent the rear side of the semiconductor stack, a cover glass spaced rearwardly of the cathode and covering the solar panel, and a peripheral sealant bonding the cover glass to the transparent front sheet.

10. The active matrix display of claim 9 in which the peripheral sealant holds the cover glass spaced away from the rear side of the cathode to form an air gap between the cathode and the cover glass.

11. The active matrix display of claim 8 in which the transparent front sheet is a glass substrate for the semi-transparent layer of light emissive devices.

12. The active matrix display of claim 7 in which the solar panel includes laminated N-type and P-type semiconductor materials, and includes an array of electrodes on at least one surface of said solar panel for generating said electrical output, the array of electrodes including multiple electrode segments located on the front surface of the semiconductor laminate and spaced from each other to allow light from the light emissive devices to impinge on the semiconductor laminate.

13. The active matrix display of claim 12 in which the array of electrodes includes first spaced electrode segments running in a first direction on one surface of the semiconductor laminate, and second spaced electrode segments running in a second direction on the opposite surface of the semiconductor laminate.

14. The active matrix display of claim 7 in which the semi-transparent layer of light emissive devices includes a substantially transparent anode and a semi-transparent cathode.

15. The active matrix display of claim 7 in which the solar panel includes an array of electrodes on at least one surface of the solar panel for generating said electrical output, the electrical output corresponding to the light emissions from various light emissive devices across the matrix of display pixels.

16. The active matrix display of claim 15 further comprising:

a detection circuit for detecting non-uniformities in the active matrix display from the electrical output; and a correction circuit for correcting for the detected non-uniformities in the active matrix display.

17. The active matrix display of claim 16, in which the solar panel comprises a plurality of solar cell units, each solar cell unit representing one or more pixels or sub-pixels.

18. The active matrix display of claim 17, in which each solar cell unit is calibrated at different color and brightness levels, and in which values corresponding to the electrical output are stored in a lookup table for use in the detecting and the correcting of the non-uniformities in the active matrix display.

19. The active matrix display of claim 15 in which the electrodes on the at least one surface of the solar panel generates the electrical output for use in detecting the location of a change in the amount of light impinging on a portion of the front surface of the solar panel due to an object in front of the semi-transparent layer reflecting light from the emissive devices back through the semi-transparent layer to the solar panel.

20. The active matrix display of claim 19 further comprising:

a touch screen circuit coupled to the solar panel for receiving the electrical output from the array of electrodes and for detecting the location of the change in the amount of light with use of the electrical output.

21. The active matrix display of claim 7, in which the electrical output comprises electrical energy, the active matrix display further comprising:

electrical energy storage coupled to the solar panel for storing the electrical energy.

* * * * *

专利名称(译)	多功能有源矩阵有机发光二极管显示器		
公开(公告)号	US10453904	公开(公告)日	2019-10-22
申请号	US16/107672	申请日	2018-08-21
[标]申请(专利权)人(译)	伊格尼斯创新公司		
申请(专利权)人(译)	IGNIS创新INC.		
当前申请(专利权)人(译)	IGNIS创新INC.		
[标]发明人	CHAJI GHOLAMREZA TIAN BAOLIN		
发明人	CHAJI, GHOLAMREZA TIAN, BAOLIN		
IPC分类号	H01L27/32 G06F3/041 G06F3/042 G09G3/3225 H01L27/28 H01L51/52 G09G3/00 G09G3/34 H01L51/50 H01L51/00		
CPC分类号	G06F3/0421 H01L27/3227 H01L51/5234 H01L27/323 G09G3/3406 G09G3/003 H01L51/5246 H01L51/525 H01L51/5284 G06F3/042 H01L51/5206 G06F3/0412 G09G3/3225 H01L27/288 H01L51/006 H01L51/5012 H01L51/0071 H01L51/5092 H01L51/0081 H01L2251/301 H01L51/524 H01L51/5072 H01L51/5056 H01L2251/558 G09G2354/00 H01L2251/305 H01L2251/5323 G09G2358/00 H01L51/0058 H01L51/0072 H01L2251/308		
优先权	15/174174 2017-11-14 US 61/564634 2011-11-29 US		
其他公开文献	US20180358419A1		
外部链接	Espacenet		

摘要(译)

一种多功能有源矩阵显示器，包括透明的前面板，与前面板的后侧相邻并形成显示像素矩阵的发光器件的半透明层，以及位于发光器件后面的太阳能电池层，用于将来自发光器件的环境光和内部光都转换为电能，该太阳能电池层在太阳能电池层的前表面包括一个电极阵列，用于检测电池的位置。改变入射在太阳能电池层的前表面的一部分上的光量。

